

CVAT – Jednonosníkový s elektrickým vozem a se sníženou stavební výškou, zavěšení lana 2/1

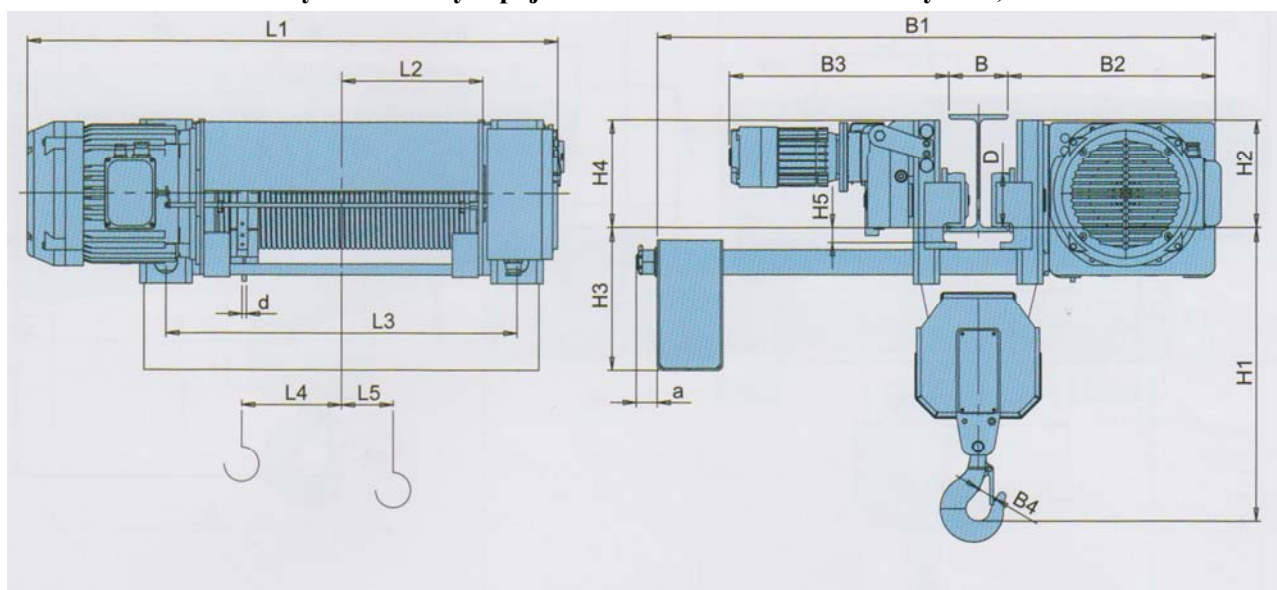

Typ	Nosnost (kg)	FEM 9.511	Výška zdvihu (m)		Rychlost zdvihu (m/min)	Rychlost pojezdu (m/min)
			H1	H2		
CVAT16 CVAT15 CVAT14	800	3m	H1	6,5	8; 12; 2/8; 2/12	8; 12; 20; 5/20
	1000	2m	H2	9		
	1250	1Am	H3	12		
			H4	18		
			H5	24		
CVAT26 CVAT25 CVAT24	1600	3m	H1	8,5	8; 12; 2/8; 2/12	8; 12; 20; 5/20
	2000	2m	H2	11,5		
	2500	1Am	H3	15		
			H4	22		
			H5	29		
CVAT36 CVAT35 CVAT34	2500	3m	H1	7,5	8; 12; 2/8; 2/12	8; 12; 20; 5/20
	3200	2m	H2	10		
	4000	1Am	H3	13		
			H4	19		
			H5	25		
CVAT46 CVAT45 CVAT44	4000	3m	H1	6,5	8; 12; 2/8; 2/12	8; 12; 16; 20; 5/16
	5000	2m	H2	9,5		
	6300	1Am	H3	12,5		
			H4	18,5		
			H5	25,5		
CVAT56 CVAT55 CVAT54	6300	3m	H2	9	8; 12; 2/8; 2/12	8; 12; 16; 20; 5/16
	8000	2m	H3	12		
	10000	1Am	H4	18		
			H5	24		

CVAT – Jednonosníkový s elektrickým pojezdem a se sníženou stavební výškou, zavěšení lana 4/1

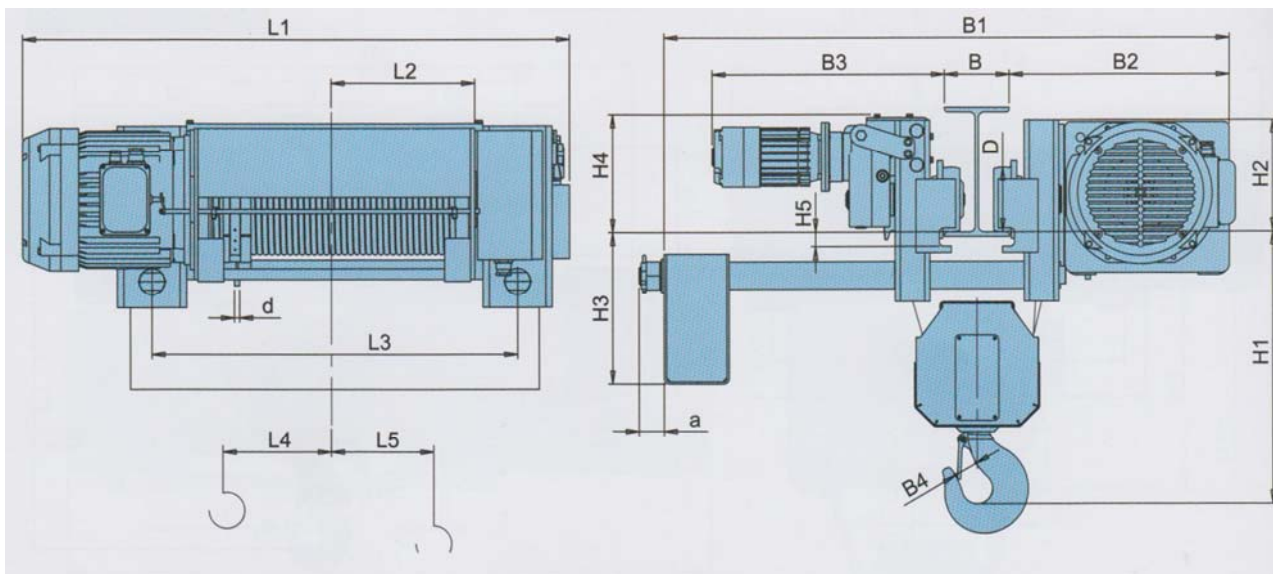

Typ	Nosnost (kg)	FEM 9.511	Výška zdvihu (m)		Rychlost zdvihu (m/min)	Rychlost pojezdu (m/min)
			H1	H2		
CVAT26	3200	3m	H1	7,5	4; 6; 1/4; 1/6	8; 12; 20; 5/20
CVAT25	4000	2m	H2	11		
CVAT24	5000	1Am	H3	14,5		
CVAT36	5000	3m	H1	6,5	4; 6; 1/4; 1/6	8; 12; 20; 5/20
CVAT35	6300	2m	H2	9,5		
CVAT34	8000	1Am	H3	12,5		
CVAT46	8000	3m	H2	9	4; 6; 1/4; 1/6	8; 12; 16; 20; 5/16
CVAT45	10000	2m	H3	12,5		
CVAT44	12500	1Am				